



INSTALLATION INSTRUCTIONS

1075 North Ave. Sanger, CA 93657-3539 toll free: 800-445-3767 web: www.belltechcorp.com

5500 REAR ASB C-1500 / C-2500 (6 Lug)

Congratulations! You were selective enough to choose a BELLTECH PRODUCT. We have spent many hours developing our line of products so that you will receive maximum performance with minimum difficulty during installation.

- Note:** Confirm that all of the hardware listed in the parts list is in the kit. **Do not** begin installation if any part is missing. Read the instructions thoroughly before beginning this installation.
- Warning:** **DO NOT** work under a vehicle supported by only a jack. Place support stands securely under the vehicle in the manufacturer's specified locations unless otherwise instructed.
- Warning:** **DO NOT** drive vehicle until all work has been completed and checked. Torque all hardware to values specified.
- Reminder:** Proper use of safety equipment and eye/face/hand protection is absolutely necessary when using these tools to perform procedures!
- Note:** It is very helpful to have an assistant available during installation.

RECOMMENDED TOOLS:

- Properly rated floor jack, support stands, and wheel chocks
- Combination wrench set
- Torque wrench: *0-75 lb ft. range*
- Ratcheting socket wrench and sockets sets
- Safety Glasses

KIT INSTALLATION

1. Open the hardware kit and remove all of the contents. Refer to the part list (Page 3) to verify that all parts are present.
2. Park the vehicle on a smooth, level concrete or seasoned asphalt surface and activate the parking brake. Block the FRONT wheels of the vehicle with appropriate wheel chocks; making sure the vehicle's transmission is in 1st gear (manual) or "Park" (automatic).
3. Using a properly rated floor jack, lift the REAR wheels of the vehicle off the ground. Place support stands, rated for the vehicle's weight, and in the factory specified locations. Refer to the vehicle Owner's Manual. Prior to lowering the vehicle onto the stands, make sure the supports will securely contact the chassis.
4. It is very important that the vehicle is properly supported during this installation to prevent personal injury and chassis damage! Make sure that the supports stands are properly placed prior to performing the following procedures. We **DO NOT RECOMMEND** using wheel ramps while performing this installation.
5. Slowly lower the vehicle onto the stands and, before placing the vehicle's entire weight on them, again check that they properly and securely contact the chassis as described above. Check for possible interference with any lines, wires, cables, or other easily damaged components.

6. Remove the end links from the ends of the original equipment Anti-Sway Bar, if so equipped. Remove the bushing bracket as well. Note the position of the Anti-Sway Bar in the vehicle to ease in the installation of your new Belltech Anti-Sway Bar. Remove the original equipment Anti-Sway Bar from the vehicle.
7. Thoroughly lubricate the **inside** of your new hyperthane bushings using the grease packet included with the kit. Place the bushings on the Anti-Sway Bar. Refer to the diagram for the proper bushing location.
8. Install the 3.25" U-clamps over the axle tubes, making sure the brake lines are not clamped underneath. Carefully bend the hydraulic lines away from the rear end if required. Place plate and bushing bracket on U-clamp and hand tighten one nut and leave one side off for now. Position the bar below the axle housing.
9. Center the Anti-Sway Bar left to the right and front to rear. The Anti-Sway Bar must be directly below the axle tubes. Position the clamps to the widest spacing possible; this prevents the bar from shifting left or right while cornering. Torque U-bolts to 28-32 ft/lb.
10. Raise the rear axle of the vehicle until the jack stands are just beginning to unload. Check for vehicle stability. Raise the ends of the Anti-Sway Bar until the vertical distance from the top side of the end of the Anti-Sway Bar to the bottom side of the frame rail is 3 7/8" for lowered trucks or 6 7/8" for stock height trucks (see parts list for correct end link lengths). Mark the location directly over the hole in the end of the Anti-Sway Bar on the bottom side of the frame rails.
11. Lower the rear axle back down and check for vehicle stability. Drill through the bottom flange of the frame rails at the marked locations with a 9/16" drill bit. **CAUTION:** Before drilling, check for electrical, fuel, or brake system components on the inside of the frame rail being drilled. Relocate components as necessary so that they are not damaged during the drilling operation.
12. Assemble the end links through the frame rails and the ends of the Anti-Sway Bar as shown in the diagram. Tighten the hardware only to the point that the steel spacer sleeve can still be forced to rotate on the bolt by hand. **NOTE:** It may be necessary to re-install the wheels and tires and lower the vehicle back down onto the ground to properly install and tighten the end link hardware.
13. All hardware being fastened to the vehicle's original fastening points should be torqued to the proper specifications. To prevent chassis damage, never over-torque the hardware.
14. Check that all components and fasteners have been properly installed, tightened and torqued.
15. Check brake hoses, and other components for any possible interference.
16. Lift vehicle and remove support stands. Carefully lower vehicle to ground.
17. Immediately test-drive the vehicle in a remote location so that you can become accustomed to the revised driving characteristics and handling. Be aware that the vehicle will handle substantially different now that it has been modified.
18. Installation is complete. Check all of the hardware and re-torque at intervals for the first 10, 100, 1000 miles.

PART LIST FOR ANTI-SWAY BAR KIT

PART No.	DESCRIPTION	QTY.
5500-300	Rear ASB	1
110255	Nylon Insert Lock Nut 3/8" -16	6
110625	Flat Washer 3/8"	4
112088	HH Cap Screw 3/8" -16 x 10"	2
112140	HH Cap Screw 3/8" -16 x 7"	2
112260	U-Clamp 3-1/4"	2
112422	Spacer Tube 1/2" x .049 x 2.50"	2
112456	Spacer Tube 5 1/2" x 3/8"	2
112502	Cup Washer Large	8
113000	End Link Grommet	8
113075	Pivot Bushing 1"	2
114026	Pivot Bushing Bracket	2
114038	Under Bushing Support Plate	2
55000-10	Grease Pack	1

! BELLTECH INSTALLATION TIPS

LUBRICATION

Pre-lubricating the inside of the bushing before it's installed is important because the lubrication will greatly reduce noise and it will increase bushing life. Belltech recommends you use Molybdenum disulfide. This will help protect the inside surface of the bushing and will last longer than most types of grease. Thoroughly lubricate the inside of the bushing with this grease.

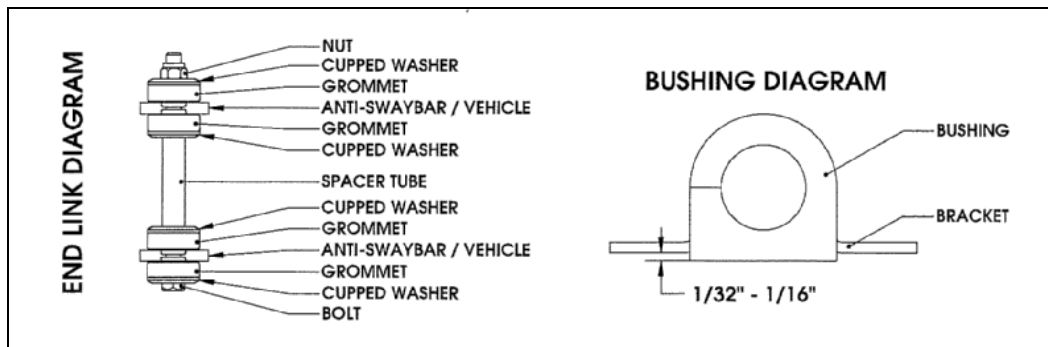

BUSHING INSTALLATION

Make sure an amount of 1/32" to 1/16" of the bushing is showing when you install it onto the bracket. See the diagram above. If the bushing is showing more than 1/16" than use a sander or a sheet of coarse grit sand paper to shave it down to the proper height. In most applications when installing the new bushings on your Belltech Anti-Sway Bar you may refer to your original equipment Anti-Sway Bar to locate the proper location.

END LINK INSTALLATION

It is not required that you use lubricant on the end links since there is not any rotational movement. The Belltech end links are comprised of grommets, cupped washers, a spacer tube, bolt, and lock nut, these assembled components create the end link. See END LINK DIAGRAM on Page 3.

AXLE CLAMP DIAGRAM

