



5546
INSTALLATION INSTRUCTIONS
FORD F-150 REAR ANTI-SWAYBAR

5546-888

7/22/98

Congratulations! You were selective enough to choose a **BELLTECH** product. We have spent many hours developing our line of products so that you will receive maximum performance with minimum difficulty in installation.

NOTE: PLEASE READ THE INSTRUCTIONS FROM START TO FINISH BEFORE BEGINNING THE INSTALLATION PROCEDURE. IF YOU DO NOT FEEL COMFORTABLE WITH THE INSTALLATION PROCEDURE, PLEASE USE A QUALIFIED MECHANIC.

WARNING: DO NOT WORK UNDER A VEHICLE BEING HELD UP BY A JACK. PLACE JACK STANDS SECURELY UNDER THE VEHICLE IN THE MANUFACTURER'S SPECIFIED LOCATIONS, UNLESS INSTRUCTED AS TO A DIFFERENT LOCATION.

1. Park the vehicle on a smooth level asphalt or concrete surface and set the parking brake firmly. Place a block in front of and behind the front wheels. Raise the rear of the vehicle with a floor jack and place jack stands securely under the vehicle in the manufacturer's specified location. Check the vehicle for stability and remove the wheels.
 2. To determine the proper mounting position of the new BELLTECH anti-sway bar, lay it on a flat surface. The center hump and the ends of the bar should both point down at a slight angle.
 3. Thoroughly lubricate the **inside** of your new urethane bushings using the lubricant provided. Position the bushings on the new anti-sway bar next to the outer most bends.
 4. Install the 3" U-clamps over the axle tubes. **Make sure the brake lines are not underneath the clamps, or brake failure may occur.** Carefully bend the brake lines, slightly, out of the way if necessary, being very careful not to kink them. Fasten the under bushing support plates and bushing brackets on the U-clamp and hand tighten one nut and washer for each bracket, leaving one side off for now. Assemble the clamps and brackets in such a way that positions the bar below and slightly forward of the axle housing, enough to clear the lower shock mounts. (see diagram)
 5. Center the anti-sway bar left to right and front to rear, and position the clamps to the widest spacing possible to prevent the bar from shifting while cornering. Assemble the pivot bushings into the bushing brackets, using all four nuts and washers, and tighten the U-bolts to 18ft/lbs of torque.
 6. Locate the spring hanger at the front of the leaf spring on the passenger side. There are four rivets securing it to the frame. From the rear lower rivet, measure back 9 1/4", and mark the bottom of the frame. Check to see if there are any wires or brake lines in the way before drilling, and carefully move them out of the way if necessary. Center punch and drill a 5/8" diameter hole in the center of the frame rail, at the 9 1/4" mark. There is an existing hole in the same spot on the driver's side, if necessary, enlarge it to 5/8" diameter also. Swing the bar up and position the ends of the arms parallel with the frame rails, under the holes you drilled. Assemble the end links as shown in the diagram. **NOTE:** Stock height vehicles will use the long bolts and spacer tubes, for the end links, and lowered vehicles will use the short one's.
 7. Assemble the end links to the frame and the anti-sway bar, as shown in the diagram. Tighten the end link grommets until they just begin to bulge, but do not crush them.
- Go over the entire installation procedure and make sure all appropriate fasteners are properly tight. Install the wheels and lower the vehicle. Installation is complete.

5546
PARTS LIST

'97 FORD F-150 REAR ANTI-SWAYBAR

7/22/98

| | | | |
|---|---|----------|------------------------------------|
| 1 | - | 5546-001 | ANTI - SWAYBAR |
| 2 | - | 114026 | PIVOT BUSHING BRACKET |
| 2 | - | 114038 | UNDER BUSHING SUPPORT PLATES |
| 8 | - | 113000 | END LINK GROMMET |
| 2 | - | 113075 | URETHANE PIVOT BUSHING |
| 2 | - | 112140 | 3/8" - 16 X 7" HEX HEAD CAP SCREW |
| 2 | - | 112088 | 3/8" - 16 x 10" HEX HEAD CAP SCREW |
| 8 | - | 112502 | CUPPED WASHER |
| 4 | - | 110625 | 3/8" SAE FLAT WASHER |
| 2 | - | 112258 | 3" U-CLAMP |
| 6 | - | 110255 | 3/8" - 16 NYLOCK NUT |
| 2 | - | 112422 | 3/8" x 2-1/2" SPACER TUBE |
| 2 | - | 112456 | 3/8" x 5 1/2" SPACER TUBE |
| 1 | - | 55000-10 | GREASE PACK |
| 1 | - | 5546-888 | INSTALLATION INSTRUCTIONS |
| 1 | - | 5546-886 | DIAGRAM |

(Passenger Side)
To Front
Of Vehicle

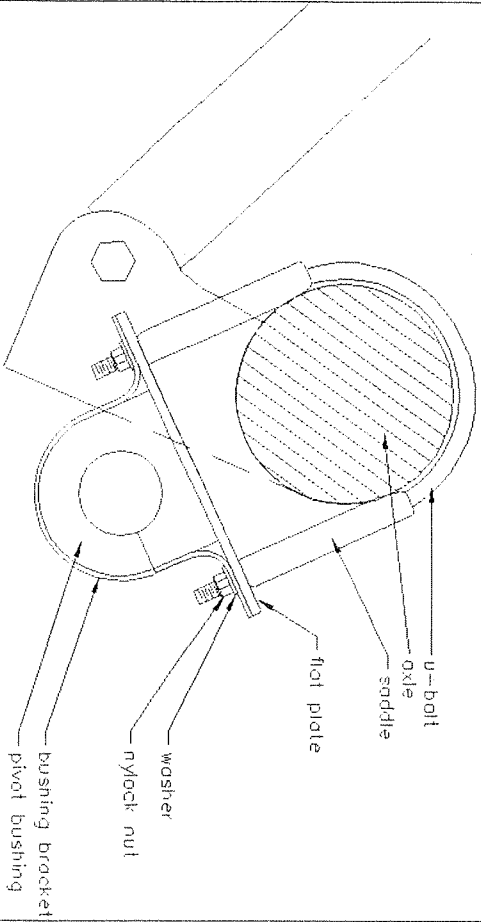

U-CLAMP AND PIVOT BUSHING
VIEW NOT TO SCALE

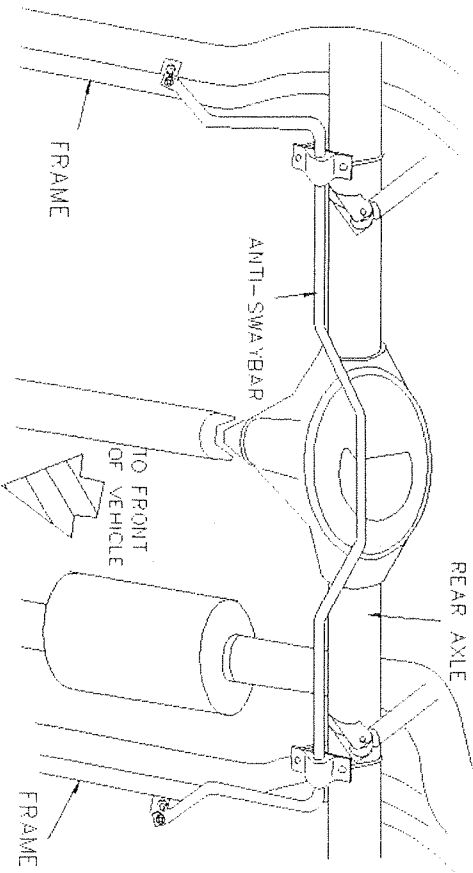

use the 7" bolt on lowered vehicles
use the 10" bolt on stock height vehicle

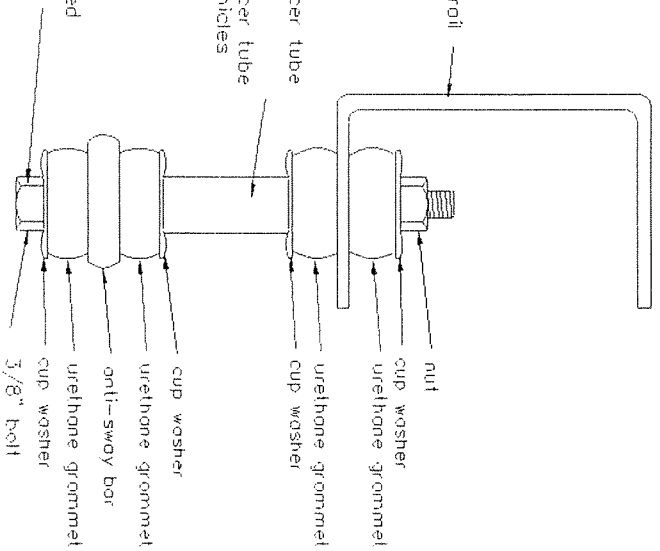

ENDLINK ASSEMBLY
VIEW NOT TO SCALE

use the 2 1/2" spacer tube on lowered vehicles
use the 5 1/2" spacer tube on stock height vehicles

5546
7/6/98
SW